

Single Band 5GHz 2x2 802.11ac Wave 2 MiniPCle WiFi Module Designed for Next Generation 802.11ac Wave 2 Access Points

Model: WLE650V5-18A



KEY FEATURES

- Qualcomm Atheros QCA9888
- 5GHz, 2x2 MIMO OFDM Technology, up to 867Mbps physical data rate
- Single Band 5GHz 2x2 WiFi 5 (802.11ac Wave 2)
- MiniPCle interface with PCIe 1.2
- 2 spatial streams (2SS) at 80MHz bandwidth
- 1 spatial stream (1SS) at 80+80MHz bandwidth
- IEEE 802.11ac compliant & backward compatible with 802.11a/n
- Heat sink allows free air operation
- Supports Spatial Multiplexing, Cyclic Delay Diversity (CDD), Low-Density Parity-Check (LDPC) Codes, Maximal Ratio Combining (MRC), Space Time Block Code (STBC)
- Supports IEEE 802.11d, e, h, i, k, r, v time stamp, and w standards
- Supports Dynamic Frequency Selection (DFS)

Specifications

Chipset	Qualcomm Atheros QCA9888 'Besra' Series
Reference Design	Qualcomm Atheros BSR02
Host Interface	MiniPCle interface with PCIe 1.2
Operating Voltage	3.3V
Power Consumption	5.6W (Max)
Wireless	5GHz 802.11a/n/ac, max 18dBm per chain 2x U.FL Connectors
Frequency Range	5.150~5.825GHz
Modulation Techniques	BPSK, QPSK, DBPSK, DQPSK, 16-QAM, 64-QAM, 256-QAM
Channel Spectrum Widths for WLAN	Supports 20/40/80/80+80MHz at 5GHz
ESD Sensitivity	Class 1C
Supported Operating System	CompexWRT \geq v3.1.3 or OpenWRT/LEDE kernel \geq v4.13.0 on WPJ558, WPJ563, WPQ864, and WPQ865
Certification	REACH and RoHS Compliance
Environmental Temperature	Operating: -20°C to 70°C, Storage: -40°C to 90°C
Environmental Humidity, Non-Condensing	Operating: 5% to 95%, Storage: Max. 90%
Dimensions (W x H x D) in mm	29.9 x 50.8 x 10.4

[1] Older prototypes (WLE650V5-18) contain QCA9886.

*Configurations are subject to change without notifications.

RF Performance Table for 5GHz

	Data Rate	TX Power (per chain)	TX Power (2 chains)	Tolerance
5GHz 802.11a	6Mbps	18dBm	21dBm	±2dB
	9Mbps	18dBm	21dBm	±2dB
	12Mbps	18dBm	21dBm	±2dB
	18Mbps	18dBm	21dBm	±2dB
	24Mbps	18dBm	21dBm	±2dB
	36Mbps	18dBm	21dBm	±2dB
	48Mbps	17dBm	20dBm	±2dB
	54Mbps	16dBm	19dBm	±2dB
5GHz 802.11n/ac VHT20	MCS 0	18dBm	21dBm	±2dB
	MCS 1	18dBm	21dBm	±2dB
	MCS 2	18dBm	21dBm	±2dB
	MCS 3	18dBm	21dBm	±2dB
	MCS 4	17dBm	20dBm	±2dB
	MCS 5	16dBm	19dBm	±2dB
	MCS 6	16dBm	19dBm	±2dB
	MCS 7	15dBm	18dBm	±2dB
	MCS 8	14dBm	17dBm	±2dB
5GHz 802.11n/ac VHT40	MCS 0	18dBm	21dBm	±2dB
	MCS 1	18dBm	21dBm	±2dB
	MCS 2	18dBm	21dBm	±2dB
	MCS 3	18dBm	21dBm	±2dB
	MCS 4	17dBm	20dBm	±2dB
	MCS 5	16dBm	19dBm	±2dB
	MCS 6	16dBm	19dBm	±2dB
	MCS 7	15dBm	18dBm	±2dB
	MCS 8	14dBm	17dBm	±2dB
	MCS 9	13dBm	16dBm	±2dB
5GHz 802.11ac VHT80	MCS 0	18dBm	21dBm	±2dB
	MCS 1	18dBm	21dBm	±2dB
	MCS 2	18dBm	21dBm	±2dB
	MCS 3	18dBm	21dBm	±2dB
	MCS 4	17dBm	20dBm	±2dB
	MCS 5	16dBm	19dBm	±2dB
	MCS 6	16dBm	19dBm	±2dB
	MCS 7	15dBm	18dBm	±2dB
	MCS 8	14dBm	17dBm	±2dB
	MCS 9	13dBm	16dBm	±2dB
5GHz 802.11ac VHT80+80	MCS 0	15dBm	18dBm	±2dB
	MCS 1	15dBm	18dBm	±2dB
	MCS 2	15dBm	18dBm	±2dB
	MCS 3	15dBm	18dBm	±2dB
	MCS 4	15dBm	18dBm	±2dB
	MCS 5	14dBm	17dBm	±2dB
	MCS 6	13dBm	16dBm	±2dB
	MCS 7	12dBm	15dBm	±2dB
	MCS 8	11dBm	14dBm	±2dB
	MCS 9	11dBm	14dBm	±2dB

	Data Rate	RX Specifications Sensitivity	Tolerance
5GHz 802.11a	6Mbps	-94dBm	±2dB
	9Mbps	-93dBm	±2dB
	12Mbps	-92dBm	±2dB
	18Mbps	-90dBm	±2dB
	24Mbps	-87dBm	±2dB
	36Mbps	-83dBm	±2dB
	48Mbps	-78dBm	±2dB
	54Mbps	-76dBm	±2dB
5GHz 802.11n/ac VHT20	MCS 0	-92dBm	±2dB
	MCS 1	-88dBm	±2dB
	MCS 2	-85dBm	±2dB
	MCS 3	-83dBm	±2dB
	MCS 4	-79dBm	±2dB
	MCS 5	-73dBm	±2dB
	MCS 6	-71dBm	±2dB
	MCS 7	-71dBm	±2dB
	MCS 8	-67dBm	±2dB
5GHz 802.11n/ac VHT40	MCS 0	-87dBm	±2dB
	MCS 1	-84dBm	±2dB
	MCS 2	-81dBm	±2dB
	MCS 3	-79dBm	±2dB
	MCS 4	-75dBm	±2dB
	MCS 5	-71dBm	±2dB
	MCS 6	-70dBm	±2dB
	MCS 7	-68dBm	±2dB
	MCS 8	-64dBm	±2dB
	MCS 9	-62dBm	±2dB
5GHz 802.11ac VHT80	MCS 0	-84dBm	±2dB
	MCS 1	-81dBm	±2dB
	MCS 2	-78dBm	±2dB
	MCS 3	-76dBm	±2dB
	MCS 4	-71dBm	±2dB
	MCS 5	-67dBm	±2dB
	MCS 6	-66dBm	±2dB
	MCS 7	-64dBm	±2dB
	MCS 8	-60dBm	±2dB
	MCS 9	-58dBm	±2dB

Component Map

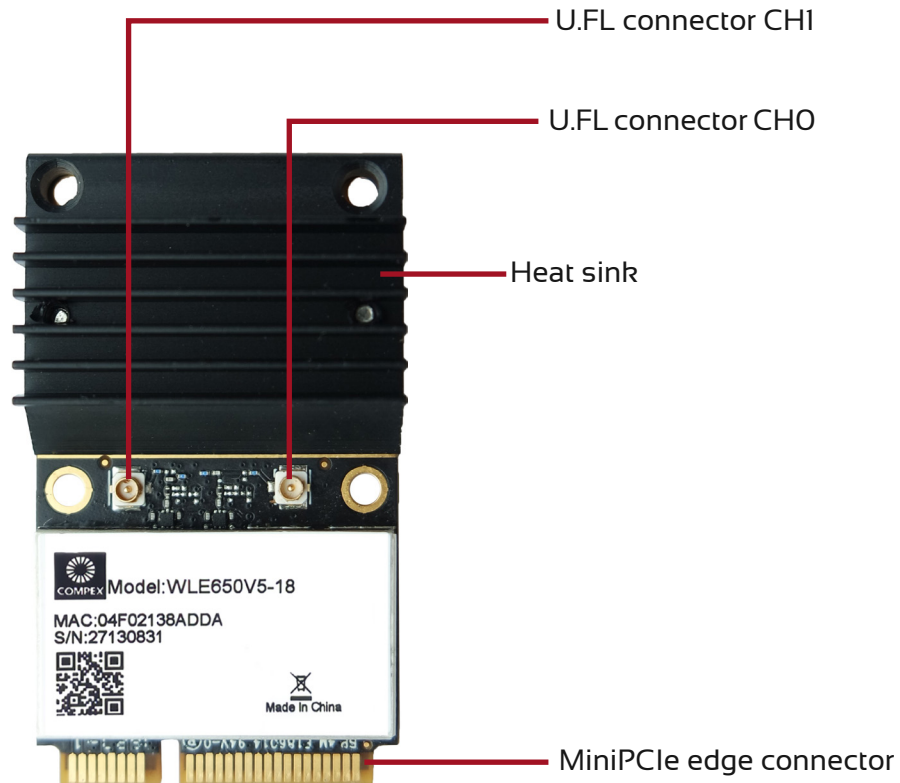

Mechanical Dimensions

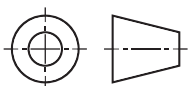
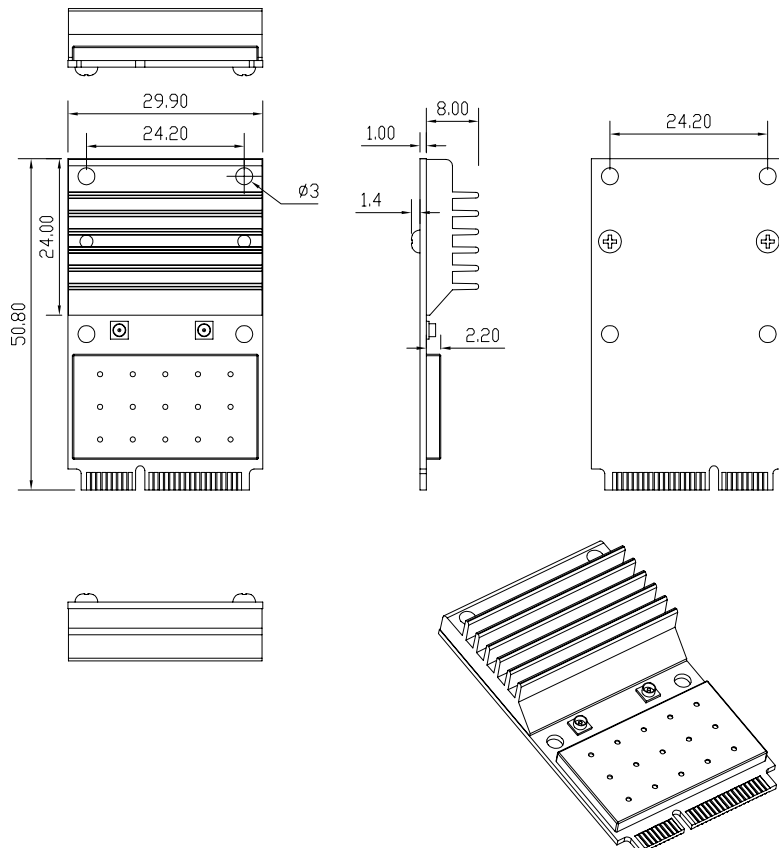

All dimensions are in mm.

Heatsink Options

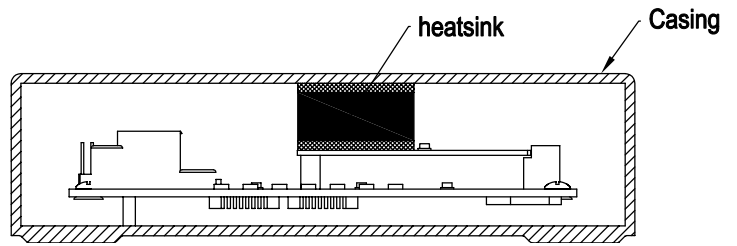
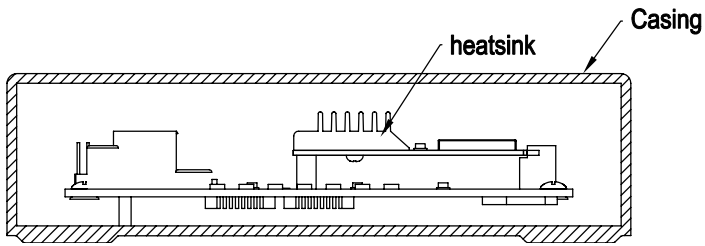

Ordering Configuration

Item Code	Model	Description
WLE650V5-18A 7A0000	WLE650V5-18A	2x2 802.11a/n/ac 5GHz miniPCIe card